

DL850 ScopeCorder

DL850V ScopeCorder Vehicle Edition

*High Speed, Multichannel and Isolated
Noise-resistant, Ultra-fast Memory Recorder*

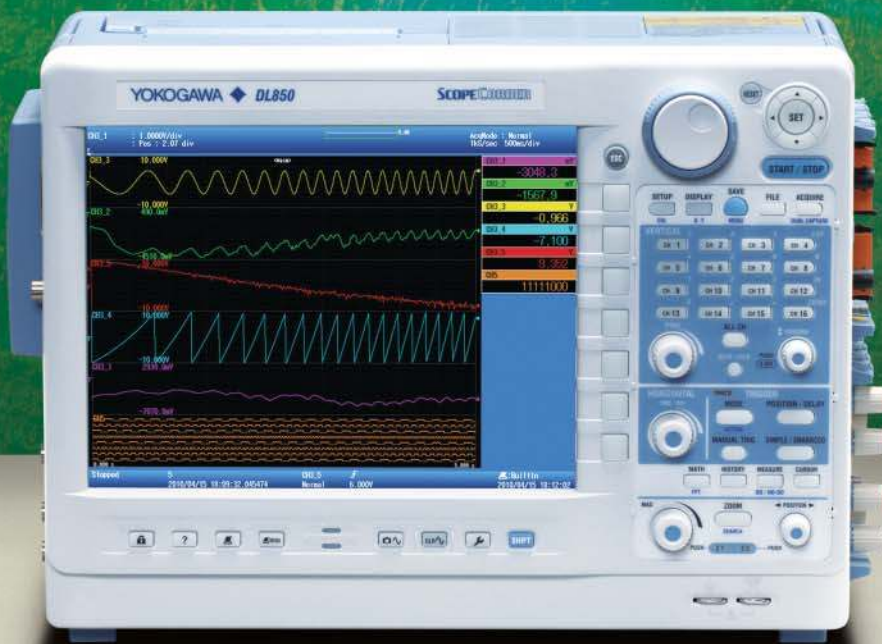

- High-speed (up to 100 MS/s), High Resolution (up to 16-bit), Isolated (up to 1kV^{*1})
- Multichannel, 128-CH voltage/temperature, 128-bit logic measurement
- Continuous hard disk recording at 100 kS/s simultaneously on 16 channels^{*2}
- Monitors CAN and LIN buses to display trend waveforms (DL850V only)
- 17 types of plug-in modules

*1. With the isolated probe (700929 or 701947)

*2. With the /HD0 or /HD1 option

For more information, please visit:

tmi.yokogawa.com

Test & Measurement Instruments



Measure Fast Signals with High Accuracy and Time Resolution

The DL850 ScopeCorder Series are modular, waveform recording instruments that can measure voltage, current, strain, acceleration, and other phenomena-- simultaneously. With high speed sampling, high isolation withstand voltage, and multichannel measurements, the DL850 Series offers powerful support in the development, evaluation, and quality control of energy efficient devices.

DL850V / DL850

ScopeCorder Vehicle Edition

ScopeCorder

For increasingly fast inverter signals

High speed (100 MS/s), High resolution (12-bit), 1kV isolated measurements.* * With a combination of the high-speed isolation module and the model 700929 or 701947 probe

Yokogawa's isoPRO technology offers industry-leading isolation performance at the highest speeds. The isoPRO core technology is designed with energy savings applications in mind. It gives you the performance needed to develop high efficiency inverters, which employ high voltages, large currents, and high operating speeds.

isoPRO High speed & high withstand voltage isolation technology

Using high speed optical fiber-based transmissions, the module achieves high speed ADC clock and data isolation.

720210 High-speed 100 MS/s 12-Bit Isolation Module (Max. four (4) modules can be installed in a main unit.)

Example: Measuring inverter output
Accurately observe inverter startup waveforms with sufficient time resolution. You can confirm that no excessive overshoots occurred.

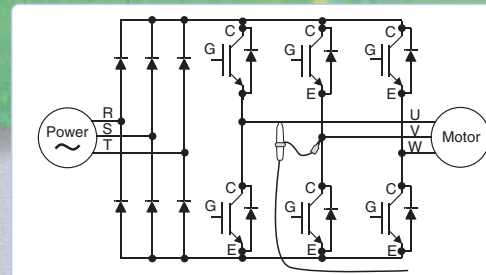

Rising waveform not completely captured

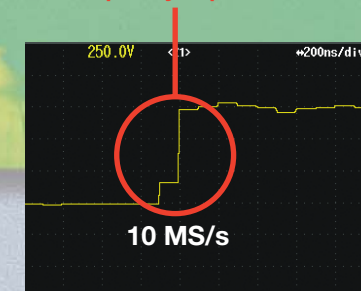

Rising waveform accurately captured

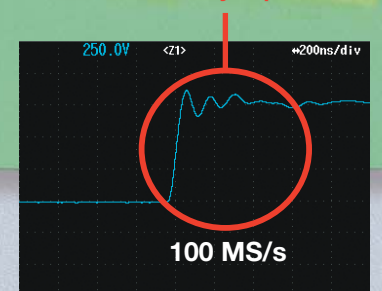

Example: Same inverter output waveform measured at 10 MS/s and 100 MS/s

Advanced-even more measurement points

Up to 128 CH of voltage input, and 128 bits of logic input

The 16-CH Voltage Input Module (scanner type) can measure at 10 kS/s sample rate even when using all 16 channels. With this module populating all 8 input module slots, the DL850 performs 128-CH voltage measurements.

The Logic Input Module supports everything from TTL levels, to high voltage contact closures at up to 10 MS/s*. With eight logic modules, the DL850 can monitor and capture 128 bits of logic.

Example: Measuring a multi-output power source
Power supplies used in home computing electronics have many outputs. With a multichannel module, you are not limited to voltage measurements; a single unit can also measure everything from PC control signals to AC fan operation and slow to high-speed signals.

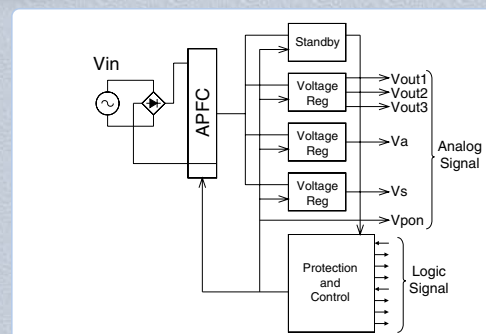

Ch 1: AC Input voltage
Ch 6: Supply voltage
Ch 2: Reference voltage
Ch 3: Reset signal

Ch 1: Fan Rotation
16-bit logic: Control Signals
4-bit logic: Serial communication



* A response time for the logic input varies according as the probe.

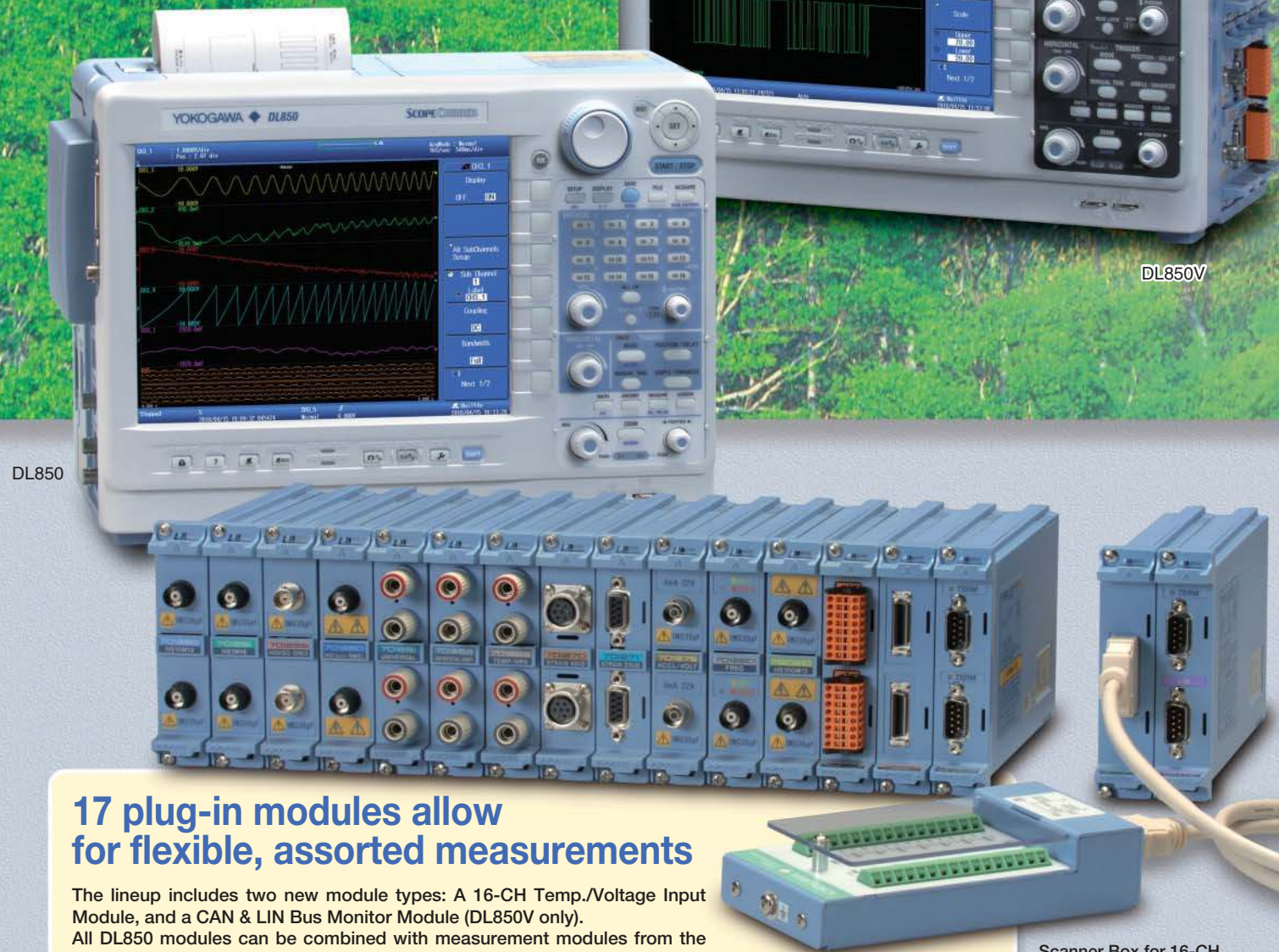

17 plug-in modules allow for flexible, assorted measurements

The lineup includes two new module types: A 16-CH Temp./Voltage Input Module, and a CAN & LIN Bus Monitor Module (DL850V only). All DL850 modules can be combined with measurement modules from the DL750 series products:

- High-speed Voltage
- High Voltage
- High-precision Voltage
- 16-CH Voltage
- Temperature
- 16-CH Temp./Voltage **NEW!**
- Strain
- Acceleration
- Frequency
- Logic Input
- CAN Monitor (DL850V only)
- CAN & LIN Monitor (DL850V only) **NEW!**

For dedicated module functions and specifications, see the module catalog (Bulletin DL850-01EN). For the 100 MS/s High-speed, 12-bit Isolation Module (model: 720210), a maximum of four modules can be installed in a single main unit.

Scanner Box for 16-CH Temp./Voltage Input Module (model: 701953)
This unit is required when making measurements.

Display and Record Vast Amounts of Data with Long Memory and Easy Operation

10.4-inch LCD XGA (1024 x 768)
The large, high resolution LCD screen displays multiple channels in precise detail

Jog shuttle
Lets you easily set parameters with wide dynamic ranges

4 directional cursor keys
With large pop-up menus and 4 directional cursor keys, it is easy to enter and modify settings with many parameters.

One Button SAVE
Select data or image format you wish to save in advance, then simply press one button to save everything at once.

ALL CH key
A spreadsheet style view of all channel settings is displayed for easy editing.

Dedicated vertical axis and zoom knobs
Direct accessibility means faster and easier settings!

Panel sheets in your language
Select an adhesive sheet in any of 8 languages for the instrument's front panel

Snapshot key
Efficiency from Settings to Measurement, Analysis, and Saving

! Large (2 GPoint) memory offers long duration measurement and two instantaneous zoom locations —2 GPoint memory (/M2 option)—

Comes standard with 250 MPoints of memory, expandable with 1 or 2 GPoint options. Large capacity memory does not simply provide longer durations of measurement.

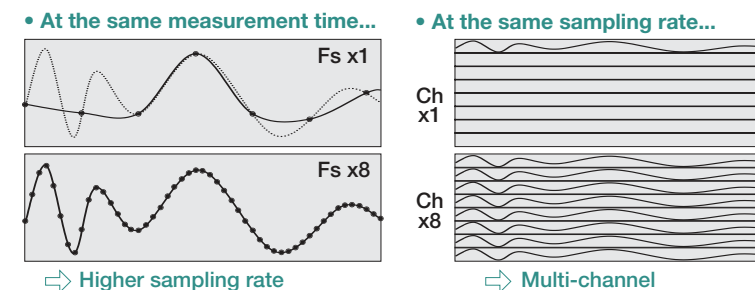

Measurements possible with a 2 GPoint long memory

Sample rate	With 1 ch	With 16 ch
100 MS/s	20 sec.	2 sec. (using 8 ch)
10 MS/s	3 min. 20 sec.	10 sec.
1 MS/s	30 min.	1 min. 40 sec.
100 kS/s	5 hours	10 min.
10 kS/s	50 hours	2 hours 30 min.
200 S/s	30 days	50 hours
20 S/s	30 days*	30 days

* 30 days is maximum.

Zoom to 2 locations instantaneously
GiGAZoom 2 ENGINE

Main screen: 20 days of recording (2 days/div)
Up to 2 million times!
Zoom screen: 1 hour (12 min/div) & 1 second (100 ms/div)

Instantly zooms 1 second (100 ms/div) even when the main screen is displaying 20 days of recording (2 days/div)

Long memory does not guarantee better efficiency if the memory handling and display engine is slow. Our faster than ever GiGAZoom 2 Engine instantaneously zooms into two locations.

! Long Duration, Continuous Saving of Waveforms —Hard disk recording (/HD0, /HD1 option)—

Measured data can be streamed directly to a built-in 160 GB hard disk (/HD1 option)¹ or through the external HDD interface (/HD0 option)¹. With long duration evaluation testing, measurements can be performed at 100 kS/s on 16 channels simultaneously for 10 hours².

¹ The /HD0 and /HD1 options cannot be specified together.
² It depends on the external hard disk connected when using the /HD0 option.

100 kS/sec with 16 ch simultaneously

Sample rate	With 1 ch	With 16 ch
1 MS/s	10 hours	-
200 kS/s	60 hours	-
100 kS/s	5 days	10 hours
20 kS/s	20 days	2.5 days
1 kS/s	30 days ²	30 days

With the /M2 option, the maximum duration depends on the memory length.
² Real time hard disk recording can be performed for a maximum of 30 days.

Performs waveform analysis without stopping measurement

Data being continuously recorded on the DL850/DL850V's built-in HDD or external HDD can be transferred to a PC without stopping measurement. You can display and analyze the transferred waveform data using Xviewer, an accessory program for the PC.

* This function is Xviewer's option

Divides and saves measured data across multiple files!

Divided files are automatically uploaded and linked.

Xviewer

Ethernet or USB

Key Point 1

If an abnormality occurs during a long duration continuous test, you can analyze the saved measured data without having to stop measurement!

Key Point 2

Easily duplicate critical measured data on the main unit and a PC

! Efficiency from Settings to Measurement, Analysis, and Saving

1. Enter input conditions in a full-screen menu
2. Easily zoom to a location of interest
3. Analyze using cursors
4. Save data for reports

A ScopeCorder Shows You the Waveforms You Want

Catch transients in durability with high-speed sampling

To visualize long term trends in durability testing and other situations, data is typically acquired at low-speed sample rates. On the other hand, suddenly-occurring transitional phenomena should be captured at high-speed sample rates. The "Dual Capture" feature resolves these conflicting requirements by recording at two different sampling rates.



Event waveform

Displays the timing at which high speed capture waveforms are acquired

Main waveform

Max: 100 kS/s
Trend waveform displayed in a low-speed Roll mode

Capture waveform

Max 100 MS/s
Capture transients with high speed trigger measurement

Zoom waveform

You can record up to 5,000 phenomena of high speed trigger measurements (up to 100 MS/s) at a record length of 5-500 kPoints while taking trend measurements at up to 100 kS/s.

— Dual capture —

Measurements with simultaneous high- and low-speed sampling

Example: Parts durability testing
Parts used in automobiles and other transportation vehicles must be highly reliable. The "Dual Capture" function is very effective when performing vibration testing of connectors under varying temperatures.

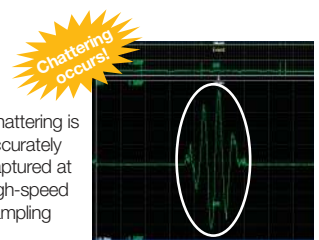

Chattering is accurately captured at high-speed sampling

Check the frequency of occurrence at low-speed sampling

Recall Past Waveforms

— History Function —

When you spot an abnormal phenomenon during repetitive high speed measurements, often the anomaly has disappeared from the screen by the time you press Stop.

Always active, the "History" function automatically divides the long memory into up to 5,000 "history waveforms" that can be redisplayed at any time.



Use the jog shuttle to display past waveforms

To extract abnormal waveforms...

To check the history...



You can display all past waveforms, and view a list of acquisition times at min 1 μs resolution

Searching history waveforms

When you want to extract specific abnormal phenomena, you can perform condition-based searches inside the history waveforms. You can create a rectangular zone on screen and extract only waveforms that pass through or do not pass through the zone. You can also extract data based on parameters such as amplitude or RMS.

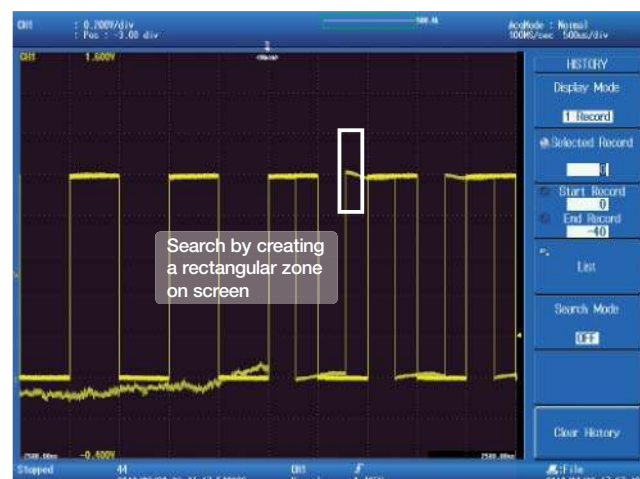

Search by creating a rectangular zone on screen

Key Point

The History function requires no action during measurement. You can recall data at any time after measurement has been completed. Once waveforms have been recalled, you can zoom locations of interest or perform parameter measurements.

Never Miss a Signal

Armed with an array of trigger functions

— Simple & Enhanced Triggers —

The DL offers easy-to-use "Simple" triggers, or lets you combine various "Enhanced" triggers for even more advanced capturing. Enhanced trigger conditions are set up intuitively in advanced, easy-to-understand graphical user interfaces.

SIMPLE

Edge: Trigger on a single trigger source condition (rising, falling, rising/falling)

Time: Trigger at a specified time or fixed interval

ENHANCED

A -> B(N): Trigger when condition B is true N times after condition A becomes true

A Delay B: After condition A becomes true, trigger the first time condition B becomes true after a set time has passed

Edge On A: Trigger on an OR condition of an edge trigger while the A trigger is true.

OR: Trigger if at least one trigger condition of multiple trigger sources is true

AND: Trigger if all trigger conditions of multiple trigger sources are true

Period: Trigger when a condition regarding the waveform period becomes true

Pulse Width: Trigger on a condition relating a pulse width condition being true with a specified time width condition.

Wave Window: Trigger when the signal passes outside of a real time template "Wave Window"

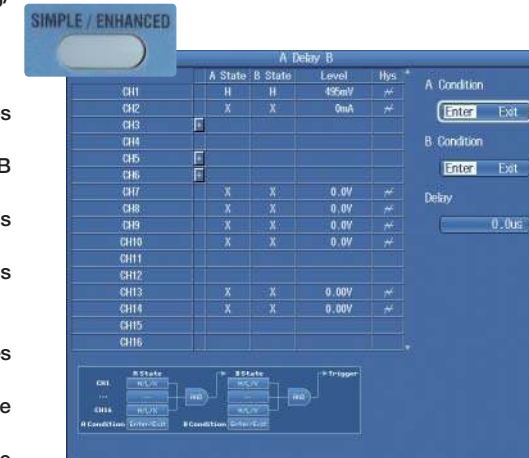

Example: "A Delay B" trigger setup screen (GUI)

— Wave Window trigger —

The Wave Window trigger is useful for diagnosing typical power supply troubles such as momentary loss, sags, and surges. It can also detect frequency changes, voltage drops, and other phenomena, with support for AC waveforms of 40 to 1,000 Hz. A reference waveform (Real time template) is compared with the current waveform, and a trigger activates if the current waveform falls outside of the allowable range. The reference waveform is generated automatically from the previous waveform in real time.

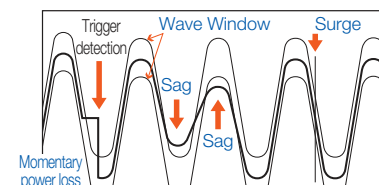

* The Wave Window is not displayed on the display.

— Action ON trigger —

To capture infrequently occurring phenomena, you can use an "Action ON Trigger" to perform multiple actions that are specified in advance when a trigger occurs.

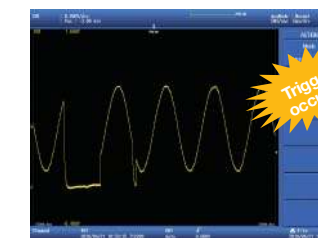

You can specify "e-mail transmission" for immediate notification in a remote location when a phenomenon occurs.

- Beep sounds
- Prints out screenshots
- Saves waveform data
- Saves screenshots
- Sends e-mails to a specified address

! Superior noise rejection

Excellent noise rejection performance is achieved through meticulous low-noise design. Floating voltage switching waveforms in inverter circuits can also be captured with precision.

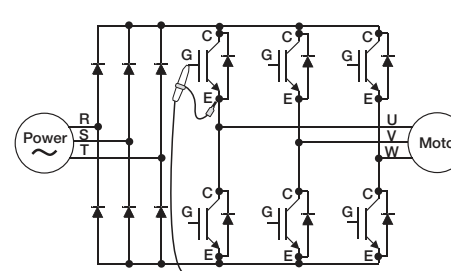

Example: Measuring inverter gate signals

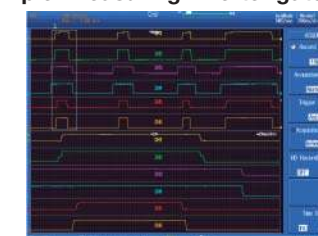

CMRR: -90dB typ @100 kHz

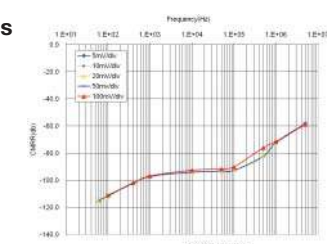

Model 701250 Voltage Input Module

Hardware Accelerated Data Processing and Math

Processes noise rejection and executes power computations in real time — Real time Math (/G3 option) —

The DL850 is armed with a dedicated DSP (digital signal processor) for computations that enables between-channel math during waveform capture. These between-channel computations are powerful because they can be set up separately from filter computations. In addition to FIR, IIR, Gauss, and moving average digital filters, you can choose from 35 unique functions such as arithmetic with coefficients, integrals and differentials, and higher-order equations.

- Display any combination of measured and math waveforms (up to 16 total).
- You can even assign channels without modules.

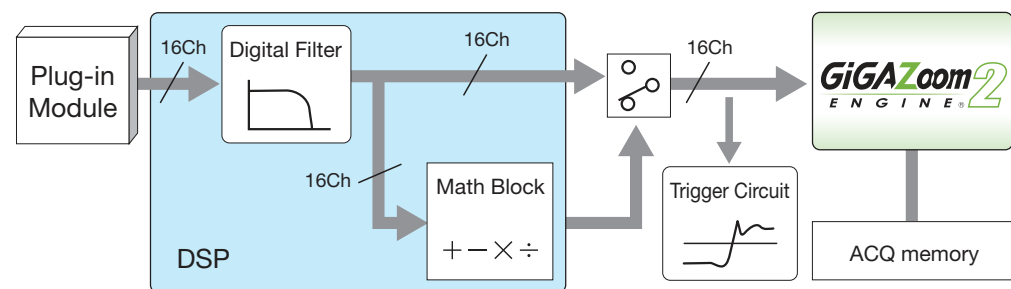

Example: 3-phase power computation
Power is calculated as the integral of the product of voltage and current over time (an average based on the period). Using the Realtime Math function, you can display 3-phase 4-wire power waveforms in real time.

$$\text{Active power } P_n = \frac{1}{T} \int V(t) \cdot I(t) dt \quad \text{3-phase 4-wire } \Sigma P^* = P1 + P2 + P3$$

* Summing the three results after performing calculation of each Pn.

Key Point

Computations occur in real time even when in Roll mode. Computed waveforms can also be used to activate triggers. Any vacant slots (CHs) can be utilized for the realtime math definition. Consequently, pre-computation waveform and post-computation waveform can be displayed simultaneously.

A wealth of functions gets you right to the waveform you want — User defined computation (/G2 option) —

The DL comes standard with arithmetic, time shift, FFT, and other computations that enable you to display waveforms with offsets and skew corrections. And with user defined computations (/G2 option), you can create equations using a combination of differentials and integrals, digital filters, and a wealth of other functions.

Example: Amplitude analysis using FFT
With the User Defined Computation function(option) included, you can perform various-types of FFT analysis using two FFT windows. In applications such as vibration and shock tests, you can easily evaluate abnormal vibrations while simultaneously measuring other signals.

User defined computation setup screen

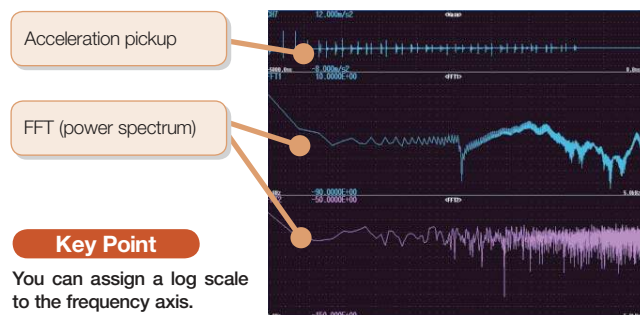

Key Point

You can assign a log scale to the frequency axis.

Automatically extract waveform amplitude, frequency, and other parameters — Waveform parameter and statistical computation —

Extract and display up to 32 parameters (amplitude, frequency, etc. including delay) simultaneously. Menus can be shown as lists of easy-to-read icons.

Statistical computation

The DL can automatically extract cycle waveforms and find the standard deviation and other statistics. Computations can be performed on history waveforms as well.



Detect abnormal waveforms, notify users, and determine pass/fail — GO/NO-GO determination —

The DL can determine whether waveforms or computed values of waveform parameters meet (GO) or do not meet (NO-GO) conditions that are specified in advance. Upon judgment of the measured results, a pre-set action is performed and users are notified that an abnormal waveform was observed, along with the pass/fail determination.

This is a very useful function for such things as studying signals from manufacturing lines of electronic devices and tracing abnormal phenomena.

Example: Evaluating motor startup characteristics

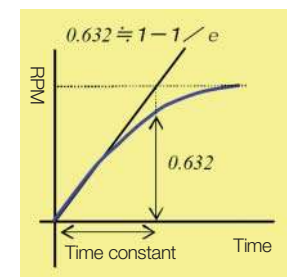

Parameter measurement is taken of the time until reaching a reference RPM after motor start, and the subsequent GO/NO-GO (pass/fail) determination is made.

New Functions, New Possibilities

Synchronize multiple units performing simultaneous measurements —IRIG input (/C20 option) —

Synchronized measurement across multiple DL850 units is made possible by inputting an IRIG time code signal.* The DL850/DL850V's internal clock is also synchronized (locked) to the IRIG signal. Therefore, timing comparisons are highly precise even when continuously recording over long periods of time.

Example: Synchronous measurements for large transport vehicles
Simultaneously measuring both tips of airplane wings, or between railroad cars requires synchronizing multiple measuring instruments in time. With a single IRIG cable, the acquisition time of all data is made the same.



Key Point

You can make periodic observations remotely by connecting commercially available GPS receivers that have IRIG output and using the Time Trigger function.

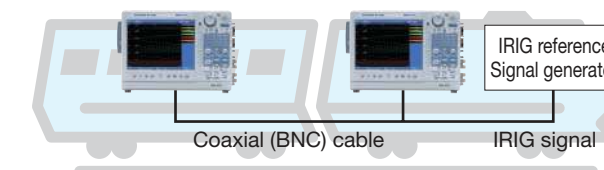

*IRIG (Inter-Range Instrumentation Group) started as an American military standard, and is now used in data recorders in the aerospace industry. The carrier frequency is a 1 kHz/10 kHz ASK (amplitude shift keying) modulating signal with a synchronizing precision of as high as 1 μs. DL850 support formats: A002, B002, A132, B122

The flexibility of an external hard drive — External hard drive interface (/HD0 option) —

With an external hard drive interface, you can connect a commercially available eSATA standard hard drive. The DL can record to an external drive in real time (see p. 5) just like it can with the built-in hard drive. After saving waveforms, you can switch the DL850/DL850V from the PC to the external drive and use the waveform data immediately.

Key Point

- (1) Ensures security**
Simply remove the drive after measurement to protect data. Or, keep restricted data only at the measurement site.
- (2) Increases capacity**
If the external hard drive becomes full, you can simply switch to a new one (requires a restart).
- (3) Hi-speed data transfer**
A data can be transferred at high speed between a PC and a hard drive.

* The external hard drive is an option when specifying the internal hard drive.
* The speed of realtime hard drive saving depends on the performance of the hard drive.



Check the relationship between hysteresis and phase — XY display function —

You can confirm the relationship between two signals using the X-Y display. This can be applied to measurements such as the phase angle of two sine waves.

Example: Computing dynamic BH characteristics of a magnetic substance
On the DL850 you can measure voltage and current, then analyze hysteresis of magnetic flux density B and magnetic field strength H. Energy loss generated by magnetostriction can be evaluated by measuring dynamic BH characteristics.

You can select four combinations on the X and Y axes, and therefore display multiple X-Y waveforms simultaneously and find relationships between them.

Simultaneous observation of X-Y waveforms and normal T-Y waveforms (waveform display using voltage and time axes) is also possible.

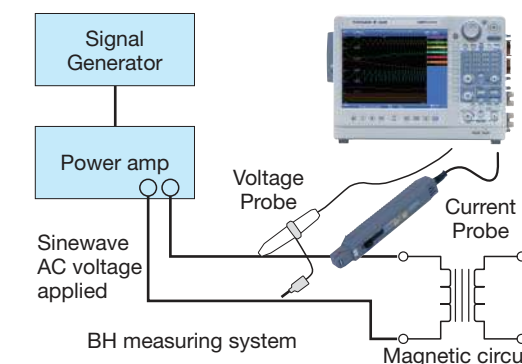

Magnetic flux density: $B = \text{Integ}(C1) / (K1 \cdot K2)$
Magnetic field strength: $H = C2 \cdot K1 / K3$
C1: voltage, C2: current
K1: number of turns, K2: cross sectional area
K3: magnetic circuit length

Special Functions

Snapshots

With the push of "SNAP SHOT" key, you can save a "snapshot" of the measured waveform (the waveform displayed on screen). The waveform remains saved even if you restart measurement, therefore you can easily compare the snapshot with any newly measured waveforms. Snapshots can also be saved and loaded as files.

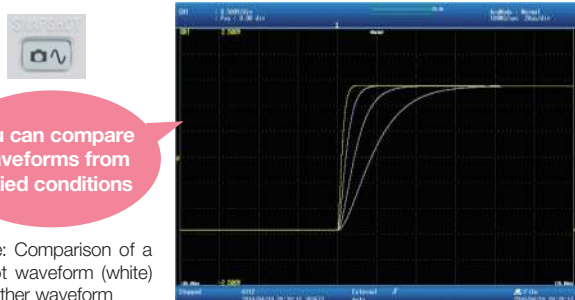

You can compare waveforms from varied conditions

Example: Comparison of a snapshot waveform (white) with another waveform

Web server

The Web Server function displays the screen of any networked DL850/DL850V on a PC via Ethernet. From this screen, you can remotely start or stop measurement, update the DL's display, and take snapshots (capture images) of the screens.

You can operate controls and acquire screen images with a Web browser—no special software required on the PC.

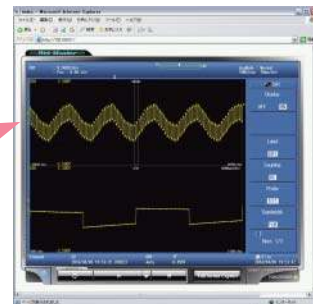

Multilanguage support

Adhesive front panel key label sheets ("panel sheets") are available in eight different languages. Multilanguage support is also provided for menus and error messages.



Saving screen images and displaying thumbnails

Screen images can be saved to a specified storage medium in PNG, JPEG, or BMP format. These screen images can be imported into reports or other PC-created documents.

Screen images saved to storage media are shown on screen as thumbnails for easy identification.

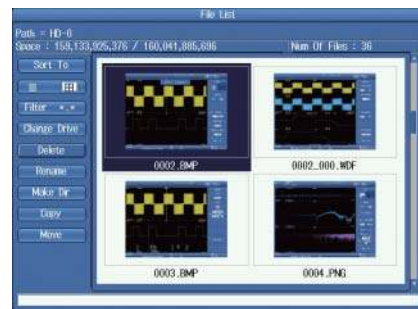

Accessory software (sold separately)

Xviewer (701992)

Xviewer is a high cost-performance, integrated waveform analysis tool offering centralized control of the ScopeCorder, measurement, data transfer, waveform observation, and analysis. The program displays waveforms measured by the DL850/DL850V on a PC and performs analysis. Waveform data (files) can be transferred from the DL850/DL850V to Xviewer via SD memory card or other media, USB, or Ethernet interface. The program supports a variety of functions for the PC

including zoom display, cursor measurements, waveform parameter computation, data conversion to CSV and other formats, creation of reports, and printing. The program not only displays and analyzes waveforms, but also displays an image of the DL850/DL850V front panel on a PC (a "control image") using the GP-IB/Ethernet/USB interface that allows you to control the instrument remotely as if you were operating its actual keys.

Model Numbers and Suffix Codes

Model	Suffix Code	Description
701992	-SP01	Xviewer Standard Edition (1 license)
	-GP01	Xviewer Math Edition (1 license)
Option	/JS01	DL850 Advanced Utility (1 license)

For details on accessory software, visit <https://y-link.yokogawa.com/YL000.po>. Also, you can download free software and trial versions of retail software from this site.

DL850V Vehicle Edition

Enhanced capabilities for vehicle design and development such as CAN & LIN Buses monitoring

The DL850V ScopeCorder Vehicle Edition can display CAN- and/or LIN-protocol communication data as trend waveforms on the display by using the CAN Bus Monitor Module (720240) or CAN & LIN Bus Monitor Module (720241). It can also trigger on decoded waveforms. By identifying the correlation between communication data on the vehicle-installed LAN and analog data such as voltage, temperature, and sensor signals or the ECU's control logic signal, a vehicle's overall LAN system can be evaluated.

Furthermore, with the /DC option, the DL850V can be driven by DC power such as the vehicle's battery, in addition to ordinary AC power.

1: The CAN & LIN Bus Monitor Module (model: 720241) is supported by the main unit firmware ver. 2.00 or later.



Utilization of Vehicle-installed Network Definition Files (CAN DBC, LIN LDF)

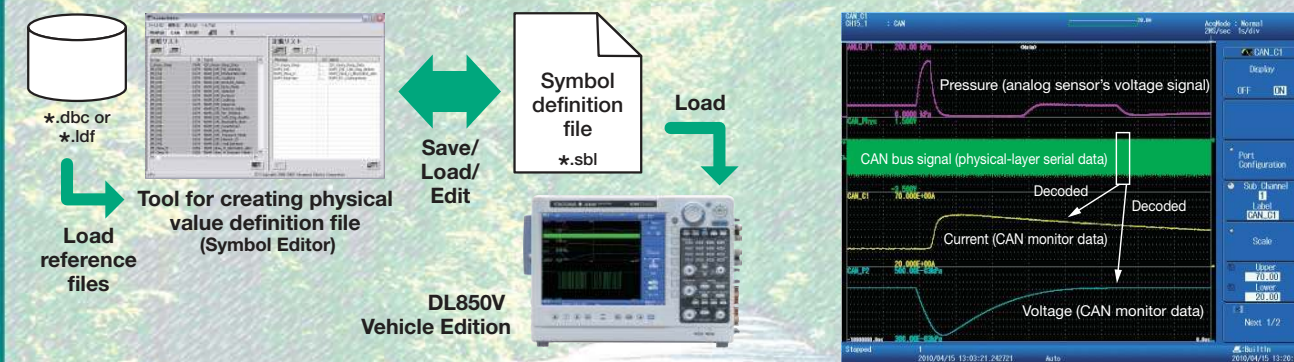

Data to be acquired using a bus monitor module (720240 or 720241) can be specified not only in digital code (hexadecimal or numeric), but also loaded from a network definition file (CAN DBC or LIN LDF).

[Example of comparison and verification of a measured signal and CAN bus signal]

You can trend the physical value of CAN bus data and the corresponding measured waveforms on the same screen at once. For example, an ignition switch ON/OFF signal, a CAN signal corresponding to that command, and an actual signal measured by a pressure sensor, etc. can be displayed and checked on the same screen, to verify the correlation of those signals.

Support for both AC and DC power (/DC option, DL850V only)

Compact thin type (Depth: 20 mm / weight: 800 g)

- Low power consumption of 60 – 120 VA (typ.)
- Low noise

- Can be driven by external DC power such as the vehicle's battery
12 V DC (10 – 18 V)
- Can also be driven by AC power.
100 V AC (100 – 120 V)
200 V AC (200 – 240 V)

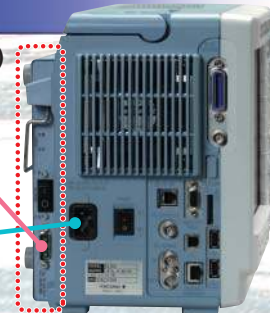

The DL850V Vehicle Edition can be driven by a 12 V DC battery, vehicle's cigarette lighter, or ordinary AC power. (We provide accessories for DC driving; see the list of accessories at the end of the catalog.)

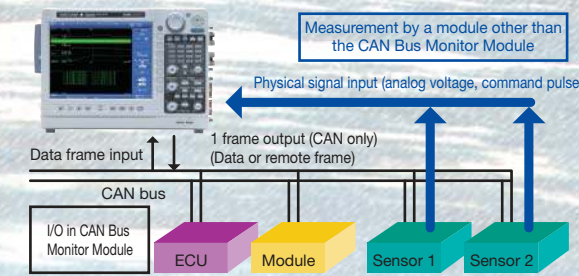

Example of accessory combinations

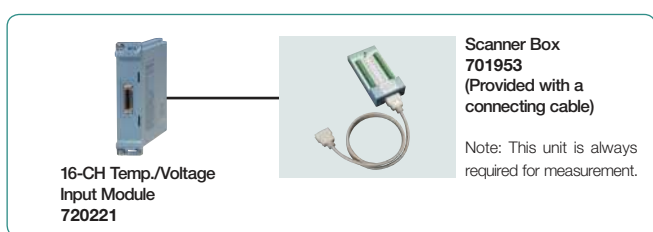
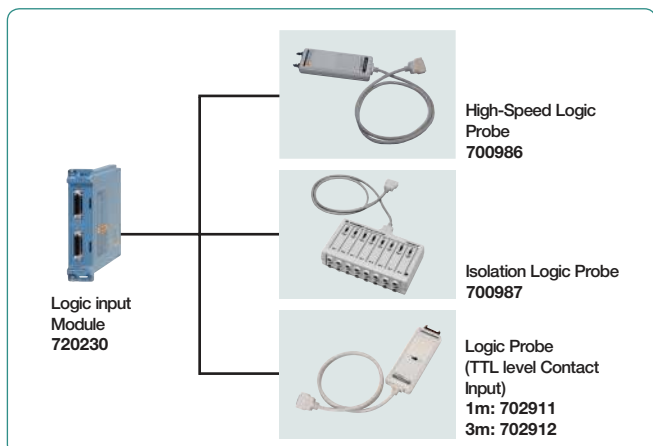
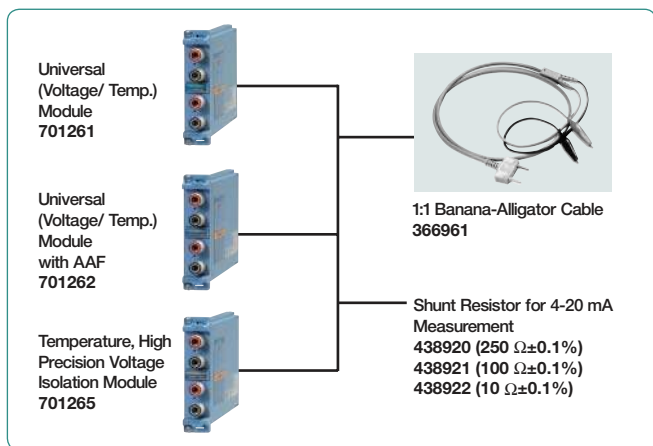
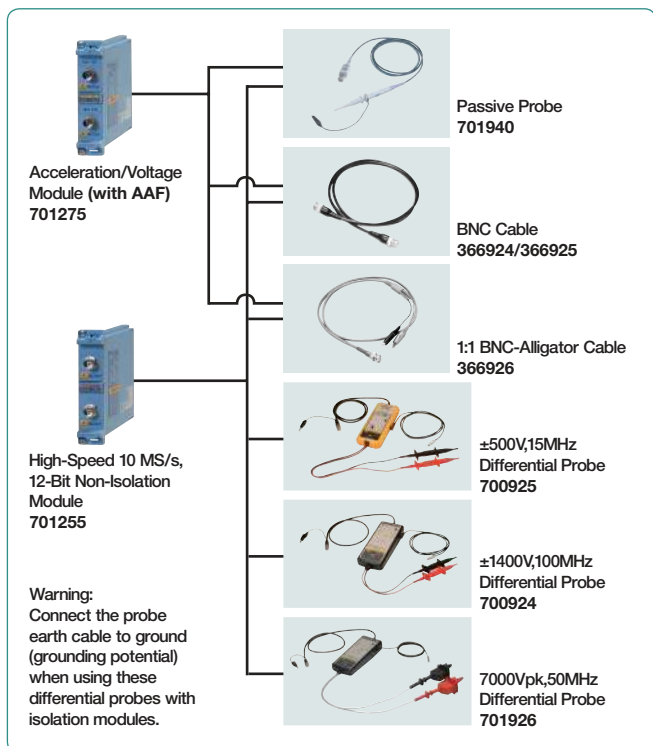
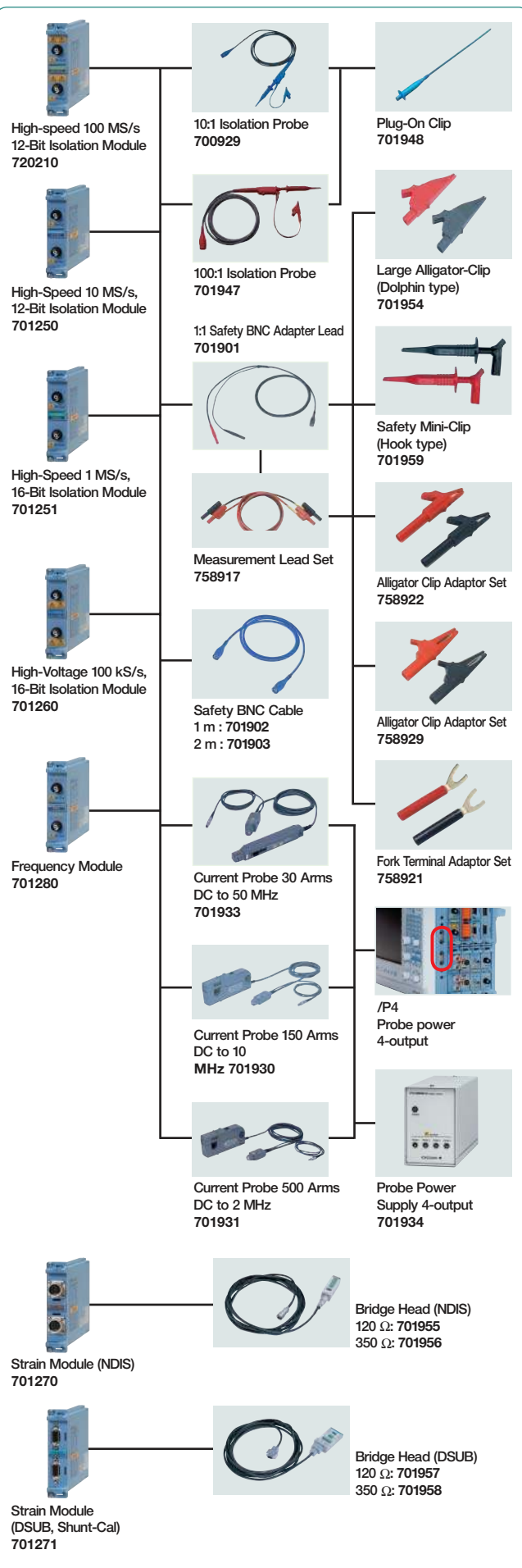

Module Selection

Input	Model No.	Sample Rate	Resolution	Bandwidth	Number of Channels	Isolation	Maximum Input Voltage (DC+ACpeak)	DC Accuracy	Note
Analog Voltage	720210	100 MS/s	12-Bit	20 MHz	2	Isolated	1000 V ² 200 V ³	±0.5%	High speed · High voltage · Isolated Max. four (4) modules can be installed in a main unit. ¹⁾
	701250 ⁵⁾	10 MS/s	12-Bit	3 MHz	2	Isolated	600 V ² 250 V ³	±0.5%	high noise immunity
	701251	1 MS/s	16-Bit	300 kHz	2	Isolated	600 V ² 140 V ³	±0.25%	High sensitivity range (1mV/div), low noise (±100 μVtyp.), and high noise immunity
	701255 ⁵⁾	10 MS/s	12-Bit	3 MHz	2	Non-Isolated	600 V ² 250 V ³	±0.5%	non-isolation version of model 701250
	701260	100 kS/s	16-Bit	40 kHz	2	Isolated	1000 V ² 850 V ³	±0.25%	with RMS, and high noise immunity
Temperature	720220	200kS/s	16-Bit	5 kHz	16	Isolated (GND-terminal non-isolated (CH-CH))	42V ³	±0.3%	16CH voltage measurement (Scan-type)
	701261	100 kS/s (Voltage), 500 S/s (Temperature)	16-Bit (Voltage), 0.1°C (Temperature)	40 kHz (Voltage), 100 Hz (Temperature)	2	Isolated	42 V	±0.25% (Voltage)	thermocouple (K, E, J, T, L, U, N, R, S, B, W, iron-doped gold/chromel)
	701262	100 kS/s (Voltage), 500 S/s (Temperature)	16-Bit (Voltage), 0.1°C (Temperature)	40 kHz (Voltage), 100 Hz (Temperature)	2	Isolated	42 V	±0.25% (Voltage)	thermocouple (K, E, J, T, L, U, N, R, S, B, W, iron-doped gold/chromel), with AAF
	701265	500 S/s (Voltage), 500 S/s (Temperature)	16-Bit (Voltage), 0.1°C (Temperature)	100 Hz	2	Isolated	42 V	±0.08 (Voltage)	thermocouple (K, E, J, T, L, U, N, R, S, B, W, iron-doped gold/chromel), high sensitivity range (0.1mV/div), and low noise (±4 μVtyp.)
Strain	720221 ¹⁾	10 S/s	16-Bit	600 Hz	16	Isolated	42 V	±0.15% (Voltage)	16-CH voltage or temperature measurement (scan method) Thermocouple (K, E, J, T, L, U, N, R, S, B, W, Au-Fe-chromel)
	701270	100 kS/s	16-Bit	20 kHz	2	Isolated	10 V	±0.5% (Strain)	Supports strain NDIS, 2, 5, 10 V built-in bridge power supply
Analog Voltage, Acceleration	701271	100 kS/s	16-Bit	20 kHz	2	Isolated	10 V	±0.5% (Strain)	Supports strain DSUB, 2, 5, 10 V built-in bridge power supply, and shunt CAL
	701275	100 kS/s	16-Bit	40 kHz	2	Isolated	42 V	±0.25% (Voltage) ±0.5% (Acceleration)	built-in anti-aliasing filter, Supports built-in amp type acceleration sensors (4 mV/22 V)
Frequency	701280	25 kS/s	16-Bit	resolution 50 ns	2	Isolated	420 V ² 42 V ³	±0.1% (Frequency)	Measurement frequency of 0.01 Hz to 200 kHz, Measured parameters (frequency, rpm, period, duty, power supply frequency, distance, speed)
Logic	720230	10 MS/s	—	—	8-bit x 2 ports	non-isolated	depend on logic probe used.	—	(8-bit/port) x 2, compatible with four-type of logic probe (sold separately)
CAN	720240	100 kS/s	—	—	60signals/2 port	Isolated	10V	—	CAN Data of max. 32-bit allowable It is available for DL850V only. Max two (2) modules can be installed in a main unit. ⁶⁾ 7)
CAN, LIN	720241	100 kS/s	—	—	60signals/2 port	Isolated	10 V (CAN port) 18 V (LIN port)	—	CAN port x 1, LIN port x 1 Available for DL850V only, up to 2 modules ⁸⁾ 7)

*1: Probes are not included with any modules. *2: In combination with 10:1 probe model 700929 *3: Direct input *4: In combination with 10:1 probe model 701940
*5: Some of the models 701250/701255 shipped on or before July, 2007 may require factory rework. *6: Any other modules can be installed in the remaining slots.
*7: Up to two CAN Bus Monitor Modules (720240) or CAN & LIN Bus Monitor Modules (720241) in total can be used on a single main unit. *8: The 16-CH Scanner Box (701953) is required for measurement.

For DL850/DL850V plug-in modules specifications, see the "Bulletin DL850-01EN" catalog.

Variety of Connection Interfaces

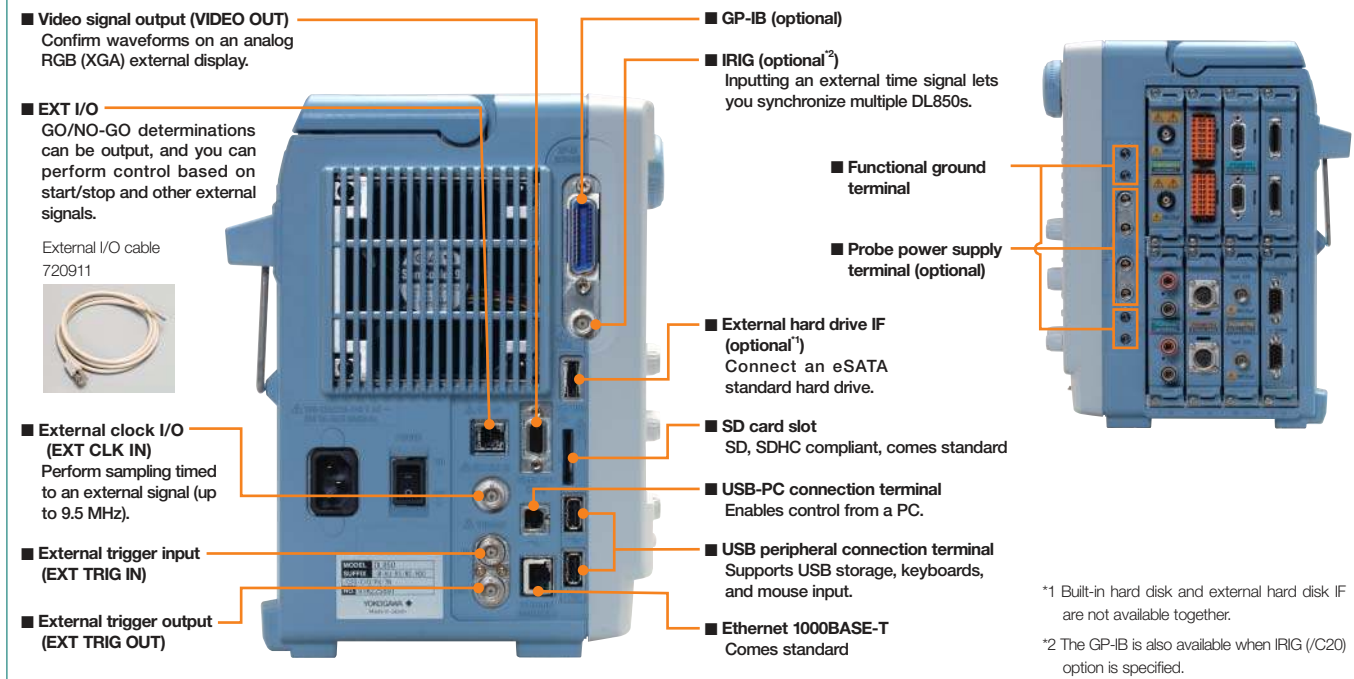

Main Specifications (Main Unit)

Main Specifications (Main Unit)	
Input Section	Plug-in module
Number of slots	8 Max 4 for 720210 modules Max 2 modules for 720240, 720241 (for DL850V only)
Number of input channels	DL850: 16CH/Slot, 128CH/Unit DL850V: 120CH/Slot, 336CH/Unit (Maximum simultaneous display waveform is 64 waveforms x 4 screen selectable)
Max recording length	Max recording length depends on kinds of modules and number of channels Standard 250 Mpts (1 CH), 10 Mpts/CH (16 CH ⁻¹) /M1 option 1 Gpts (1CH), 50 Mpts/CH (16 CH ⁻¹) /M2 option 2 Gpts (1CH), 100 Mpts/CH (16CH ⁻¹) 1 pts (point) = 1 W (word)
Time axis setting range	100ns/div to 1s/div (1-2-5 step) 2s/div, 3s/div, 4s/div, 5s/div, 6s/div, 8s/div, 10s/div, 20s/div, 30s/div, 1min/div to 10min/div (1min step), 12min/div, 15min/div, 30min/div, 1h/div to 10h/div (1h step), 12h/div, 1day/div, 2day/div, 3day/div
Time axis accuracy ²	±0.005%
Trigger Section	
Trigger mode	auto, auto level, normal, single, single (N), ON start
Trigger level setting range	0 centered ±10div
Simple trigger	
Trigger source	CHn (n: any input channel), Time, External, Line
Trigger slope	Rising, falling, or rising/falling
Time trigger	Date (year/month/day), time (hour/minute), time interval (10 seconds to 24 hours)
Enhanced trigger	
Trigger source	CHn (n: any input channel)
Trigger type	A→B(N), A Delay B, Edge on A, OR, AND, Period, Pulse Width, Wave Window
Display	
Display	10.4-inch TFT color LCD monitor, 1024×768(XGA)
Display resolution of waveform display	selectable either 801×656 (normal waveform display) or 1001×656 (wide waveform display)
Display format	Max 3 simultaneous displays available In addition to main, 2 more waveforms available among zoom 1, zoom 2, XY1, XY2, FFT1, FFT2 (/G2 option)
Function	
● Acquisition and display	
Acquisition mode	Normal Envelope Normal waveform acquisition Maximum sample rate regardless of record time, holds peak value Averaging Average count 2 to 65536 (2n steps) Box average Increase A/D resolution up to 4 bits (max 16 bits)
Roll mode	It is effective when the trigger mode is set to auto/auto level/single/ON start, and time axis is greater than 100ms/div.
Dual capture	
Main waveform (low speed)	Performs data acquisition on the same waveform at 2 different sample rates. Maximum sample rate 100kS/s (roll mode region) Maximum record length 100M point
Capture waveform (high speed)	Maximum sample rate 100MS/s Maximum record length 500k point
Realtime hard disk recording (/HDD/HD1 option)	
Maximum sample rate	Maximum 1MS/s (1CH used), 100kS/s (16CH used) depends on channel used
Capacity	Depends on HDD vacant capacity
Action	Data can be stored in the hard disc at the same time of acquisition in accordance with trigger mode.
History memory	Maximum 5000 pages
● Display	
Display format	TY display for 1, 2, 3, 4, 6, 8, 12, 16 division display
Maximum number of display traces	64 trace per 1 display group, selectable in every 4 displays
X-Y display	Selectable X axis/Y axis in CHn, MATHn (max 4 trace x 2 window)
Accumulation	Accumulates waveforms on the display (persistence mode)
Snapshot	Retains the current displayed waveform on the screen. Snapshot waveforms can be saved/loaded.
ALL CH menu	Set all channels while displaying waveforms. Operation using USB keyboard and USB mouse are available.
Expansion/reduction of vertical axis direction	×0.1 to ×100 (varies depending on the module), DIV/SPAN set selectable
Vertical position setting	±5div waveform move is available from the center of waveform screen frame.
Linear scaling	Set AX+B mode or P1-P2 mode independently for CHn

● Analysis, computation	
Cursor measurement	Horizontal, Vertical, Marker, Degree (for T-Y waveform display only), H&V
Zoom	Expand the displayed waveform along time axis (up to 2 locations using separate zoom rates) Expanded display 100ns/div to 1/2 of Main waveform Auto scroll Automatically scrolls the zoom position.
Search and zoom	Search for, then expand and display a portion of the displayed waveform. Search conditions Edge count, logic pattern, event, time
History search function	Search for and display waveforms from the history memory that satisfies specified conditions. Zone search/parameter search
Waveform parameters items	Up to 24 items can be displayed P-P, Amp, Max, Min, High, Low, Avg, Mid, Rms, Sdev, +OvrShoot, -OvrShoot, Rise, Fall, Freq, Period, +Width, -Width, Duty, Pulse, Burst1, Burst2, AvgFreq, AvgPeriod, Int1TY, Int2TY, Int1XY, Int2XY, Delay(between channels)
Statistical processing	Automated measured values of waveform parameters
Statistics	Max, Min, Avg, Sdv, Cnt
Mode	All waveforms/cycle statistics/history statistics
Maximum number of cycles	64,000 cycles (when the number of parameters is 1)
Maximum number of parameters	64,000
Maximum measurement range	100M points
Computation (MATH)	
Definable MATH waveforms	Max 8
Calculable record length	Max. 1M point (1ch)
Operators	+, -, ×, ÷, binary computation, phase shift, and power spectrum
User-defined computation (/G2 option)	Computation setting is available by combining any following operators and parameter measurement items. ABS, SORT, LOG, EXP, NEG, SIN, COS, TAN, ATAN, PH, DIF, DDIF, INTG, IINTG, BIN, P2, P3, F1, F2, FV, PWHL, PWLH, PWLL, PWXX, DUTYH, DUTYL, FLT1, FLT2, HLT, MEAN, LS-, PS-, PSD-, CS-, TF-, CH-, MAG, LOGMAG, PHASE, REAL, IMAG
FFT	
Subject to be computed	CHn, MATHn
Number of channels	1 (/G2 no option), 2 (/G2 option)
Computation points	1k/2k/5k/10k/20k/50k/100k
Time window	Rect/Hanning/Hamming/FlatTop, Exponential (/G2 option)
Average function	Yes (/G2 option)
Real time MATH (/G3 option)	
Number of computation waveforms	Maximum 16 (screen is selectable with any input channel ¹)
Digital filter	Gauss (LPF), SHARP (LPF/HPF/BPF), IIR (LPF/HPF/BPF), MEAN (LPF)
Delay	100ns to 10.00ms (The data will be decimated when the delay time is relatively long.)
Types of computation	+, -, ×, ÷, four fundamental arithmetic operations with coefficients, differential, integral, angle, D-A conversion, quartic polynomial equation, rms value, active power value, Reactive power value, integrated power value, logarithm, square root, sin, cos, atan, electrical angle, polynomial addition & subtraction, frequency, period, edge count, resolver, IIR filter, PWM, knock filter (DL850V only), and CAN ID (DL850V only)
GO/NO-GO determination	
Zone	Operate selected actions based on the determination criteria to the captured waveform. Determination using combination of up to 6 waveform zones (AND/OR).
parameters	Determination using combinations of 16 waveform parameters
Actions	Screen image data output, waveform data storage, buzzer notification, and e-mail transmission
Action-on trigger	
Actions once triggered	Operates the selected actions each time trigger occurs. Screen image data output, waveform data storage, buzzer notification, mail transmission
● Screen image data output	
Built-in printer (/B5 option)	Prints hard copy of screen.
External printer	Outputs the screen image to an external printer via Ethernet network.
File output data format	PNG, JPEG, BMP
● Other functions	
Mail transmission function	Transmission function by SMTP
PROTECT key	Key protection is available to prevent from careless or unexpected operation.
NUM key	Direct input of numerical numbers is available.
Built-in printer (/B5 option)	
Printing system	Thermal line dot system
Paper width	112mm
Effective printing width	104mm (832 dot)
Feeding direction resolution	8dot/mm
Function	Display hard copy
Storage	
SD card slot	Memory cards conforms to SD, SDHC, maximum capacity 16GB

Main Specifications (Main Unit)

USB memory	Mass storage device which conforms to USB Mass Storage Class Ver.1.1
External HDD(/HD0 option)	Hard disc conforms to eSATA
Built-in HDD(/HD1 option)	2.5 inch, 160GB, FAT32
USB peripheral interface	
Connector type	USB type A connector (receptacle) x 2
Electrical, mechanical specifications	Conforms to USB Rev.2.0*
Supported transmission standards	HS (High Speed) mode, FS (Full Speed) mode, LS (Low Speed) mode
Supported device	Mass storage device which conforms to USB Mass Storage Class Ver.1.1 109 keyboard, mouse which conform to USB HID Class Ver.1.1
Power supply	5V, 500mA (in each port) * Connect USB device directly. Composite device is not supported.
USB-PC connection	
Connector type	USB type B connector (receptacle) x1
Electrical, mechanical specifications	Conforms to USB Rev.2.0
Supported transmission standards	HS(High Speed) mode (480Mbps), FS(Full Speed) mode (12Mbps)
Supported protocol	USBTMC-USB488 (USB Test and Measurement Class Ver.1.0)
Supported system environment	Windows7(32bit)/Vista(32bit)/XP(SP2 or later, 32bit) Operates by Japanese/English language and provided with USB port
Ethernet	
Connector type	RJ-45 modular jack x1
Electrical, mechanical specifications	Conforms to IEEE802.3
Transmission system	Ethernet (1000BASE-T/100BASE-TX/10BASE-T)
Communication protocol	TCP/IP
Supported services	Server FTP, Web, VXI-11 Client SMTP, SNTP, LPR, DHCP, DNS, FTP
GP-IB (/C1, /C20 option)	
Electrical specifications	Conforms to IEEE Std 488-1978(JIS C 1901-1987)
Functional specifications	SH1, AH1, T6, L4, SR1, RL1, PP0, DC1, DT0, C0
Protocol	Conforms to IEEE Std 488.2-1992

IRIG input (/C20 option)	
Connector type	BNC connector x1
Supported IRIG signals	A002, B002, A132, B122
Input impedance	50Ω/5kΩ selectable
Maximum input voltage	±8V
Function	Main unit time synchronization, sample block synchronization
Clock synchronization range	±80ppm
Accuracy after synchronization	No drift against input signal
Auxiliary I/O section	
EXT CLK IN	BNC connector, TTL level, minimum pulse width 50ns, 9.5MHz or less
EXT TRIG IN	BNC connector, TTL level, rising/falling
EXT TRG OUT	BNC connector, 5VCMOS level, fallen when triggered, and rising when acquisition completed.
EXT I/O	Connector type RJ-11 modular jack GO/NO-GO determination I/O Input level TTL or contact input output level 5V CMOS
External start/stop input	input level TTL or contact input
Manual event	input level TTL or contact input
Video signal output	D-Sub 15 pin receptacle Analog RGB, quasi XGA output 1024×768 dot, approx 60Hz Vsync
COMP output (probe compensation signal output terminal)	1kHz±1%, 1Vp-±10%
Probe power output (/P4 option)	Number of terminals: 4, output voltage ±12V

General specifications	
Rated power supply voltage	100 to 120VAC/220 to 240VAC (automatic switching)
Rated power supply frequency	50/60Hz
Maximum power consumption	200VA
Withstand voltage	1500V AC between power supply and earth for 1 minute
Insulation resistance	10MΩ or higher at 500V DC between power supply and earth
External dimensions	Approx. 355mm (W) x 259mm (H) x 180mm (D), excluding handle and other projections
Weight	Approx. 6.5kg for main unit only, include /B5/M2/HD1/P4 options, exclude chart paper)
Operating temperature range	5 to 40 °C

12 V DC power (/DC option, for DL850V only)	
Supply method	Automatic DC/AC switching (with priority on AC), isolated between DC power input terminal and main unit
Rated supply voltage	12 V DC
Allowable supply voltage	10 to 18 V DC
Power consumption	Approx. 150 VA maximum
Voltage input protection circuit	Overcurrent detection: Breaker (15 A) Inverse connection protection: Breaker shutdown Undervoltage detection: Interruption at approx. 9.5 V or lower Overvoltage detection: Interruption at approx. 18 V or more
Withstand voltage	30 V AC between DC power terminal and ground for 1 min
Insulation resistance	10 MΩ or more at 500 V DC between DC power terminal and ground
External dimensions including the main unit	Approx. 355 mm (W) x 259 mm (H) x 202mm (D), excluding the grip and projections
Weight of DC power box	Approx. 800 g

Standard operation conditions	Ambient temperature: 23 ±5 °C Ambient humidity: 20 to 80 %RH Errors in power supply voltage/frequency: Within ±1% of rated voltage, within ±1% of rated frequency warm-up of 30 min. or more, after calibration.
-------------------------------	---

¹ Example when using the 2-CH Voltage Input Module (such as 701250)
² Under the standard operating conditions
³ It is not possible to switch a channel associated with the 16-CH Voltage Input Module (720220), 16-CH Temp./Voltage Input Module (720221), CAN Bus Monitor Module (720240), and CAN & LIN Bus Monitor Module (720241) to real-time computation.

Measurement Range and Display Range

The measurement range of the ScopeCorder is ±10 divisions (20 divisions of absolute width (span) around 0 V. The display range of the screen is ±5 divisions (10 divisions of span). The following functions can be used to move the displayed waveform and display the waveform outside the display range by expanding/reducing the displayed waveform.

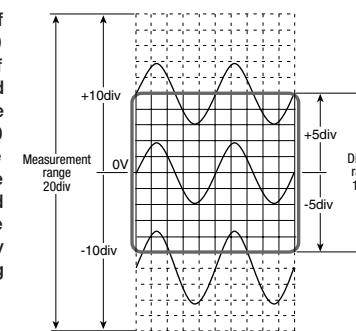

- Move the vertical position.
- Set the offset voltage.
- Zoom in or out of the vertical axis (expand/reduce).

Series related models

— SL1400/SL1000 —

SL1400 ScopeCorder LITE

- Easy operation
- Multilanguage key labels



SL1000 High-Speed Data Acquisition Unit

- High speed transfer of data to a PC
- 100 MS/s simultaneously on 16-CH
- 8 units linked



Outline drawing (Unit: mm)

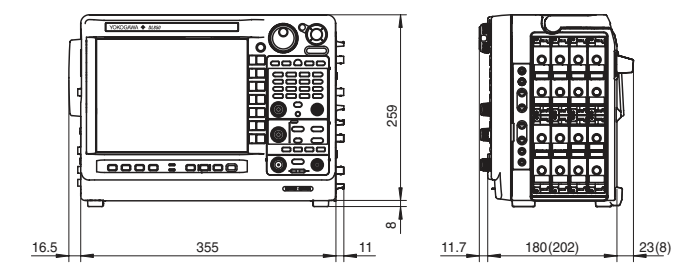

(case without /DC option)

Model/Suffix Code		
Model	Suffix Codes	Description
DL850		DL850 main unit, 250MPts(W) memory ^{*1}
DL850V		DL850V main unit, 250MPts(W) memory ^{*1}
Power Code	-D	UL and CSA standard
	-F	VDE standard
	-R	AS standard
	-Q	BS standard
	-H	GB standard
Languages	-HE	English menu and panel
	-HJ	Japanese menu and panel
	-HC	Chinese menu and panel
	-HK	Korean menu and panel
	-HG	German menu and panel
	-HF	French menu and panel
	-HL	Italian menu and panel
	-HS	Spanish menu and panel
Options	/B5	Built-in printer (112mm) ^{*5}
	/DC	DC12 V power (10-18 V DC) (can be specified for DL850V only) ^{*5}
	/M1	Memory expansion to 1Gpts(W) ^{*2}
	/M2	Memory expansion to 2Gpts(W) ^{*2}
	/HD0	External HDD interface ^{*3}
	/HD1	Internal HDD (160GB) ^{*3}
	/C1	GP-IB interface ^{*4}
	/C20	IRIG and GP-IB interface ^{*4}
	/G2	User-defined math function
	/G3	Real time math function
/P4	Four probe power outputs	

*1: The main unit is not supplied with a plug-in module.

*2, *3, *4, and *5: When selecting these, specify one of them.

Plug-in Module Model Numbers

Model	Description
720210	High-speed 100 MS/s 12-Bit Isolation Module (2 ch)
720220	Voltage Input Module(16 ch)
720221	16-CH Temperature/Voltage Input Module
701953-L1	16-CH Scanner Box (provided with 1 m cable)
701953-L3	16-CH Scanner Box (provided with 3 m cable)
720230	Logic Input Module (16 ch)
720240	CAN Bus Monitor Module (32 ch, available DL850V only)
720241	CAN & LIN Bus Monitor Module
701250	High-speed 10 MS/s 12-Bit Isolation Module (2 ch)
701251	High-speed 1 MS/s 16-Bit Isolation Module (2 ch)
701255	High-speed 10 MS/s 12-Bit non-Isolation Module (2 ch)
701260	High-voltage 100 KS/s 16-Bit Isolation Module (with RMS, 2 ch)
701261	Universal Module (2 ch)
701262	Universal Module (with Anti-Aliasing Filter, 2 ch)
701265	Temperature/high-precision voltage Module (2 ch)
701270	Strain Module (NDIS, 2 ch)
701271	Strain Module (DSUB, Shunt-CAL, 2 ch)
701275	Acceleration/Voltage Module (with Anti-Aliasing Filter, 2 ch)
701280	Frequency Module (2 ch)

* Probes are not included with any modules.

Note 1: These modules can be used with the DL750/DL750P/SL1000 and SL1400 as well with some exceptions.

Note 2: Up to two 720240 or 720241 modules in total can be installed in a single DL850V main unit.

Note 3: Max. four(4) 720210 modules can be installed in a main unit.

Note 4: The use of a 720221 module always requires the External Scanner Box (model 701953).

Note 5: The firmware ver2.00 or later is required when using 720221 and/or 720241 module.

SCOPECORDER **iSoPRO**, **GIGAzoom** are trademarks, pending trademarks or registered trademarks of Yokogawa Electric Corporation.

* Any company's names and product names mentioned in this document are trade names, trademarks or registered trademarks of their respective companies. The User's Manuals of this product are provided by CD-ROM.

Yokogawa's Approach to Preserving the Global Environment

- Yokogawa's electrical products are developed and produced in facilities that have received ISO14001 approval.
- In order to protect the global environment, Yokogawa's electrical products are designed in accordance with Yokogawa's Environmentally Friendly Product Design Guidelines and Product Design Assessment Criteria.

YOKOGAWA

YOKOGAWA METERS & INSTRUMENTS CORPORATION
 Global Sales Dept. /Phone: +81-42-534-1413 Facsimile: +81-42-534-1426
 E-mail: tm@cs.jp.yokogawa.com

YOKOGAWA CORPORATION OF AMERICA Phone: (1)-770-253-7000, Fax: (1)-770-254-0928
YOKOGAWA EUROPE B.V. Phone: (31)-88-4641000, Fax: (31)-88-4641111
YOKOGAWA ENGINEERING ASIA PTE. LTD. Phone: (65)-62419933, Fax: (65)-62412606

Probes, Cables, and Converters

Product	Model No.	Description ^{*1}
100:1 Isolation Probe	701947	1000 V (DC+ACpeak) CAT II
10:1 Probe (for isolated BNC Input)	700929	1000 V (DC+ACpeak) CAT II
1:1 Safety BNC Adapter Lead (in combination with followings)	701901	1000 Vrms-CAT II
Safety Mini-Clip (Hook type)	701959	1000 Vrms-CAT II, 1 set each of red and black
Large Alligator-Clip (Dolphin type)	701954	1000 Vrms-CAT II, 1 set each of red and black
Alligator Clip Adaptor Set (Rated Voltage 1000 V)	758929	1000 Vrms-CAT II, 1 set each of red and black
Alligator Clip Adaptor Set (Rated Voltage 300 V)	758922	300 Vrms-CAT II, 1 set each of red and black
Fork Terminal Adapter Set	758321	1000 Vrms-CAT II, 1 set each of red and black
Passive Probe ^{*2}	701940	Non-isolated 600 Vpk (701255)(10:1)
1:1 BNC-Alligator Cable	366926	Non-isolated 42 V or less, 1m
1:1 Banana-Alligator Cable	366961	Non-isolated 42 V or less, 1.2m
Current Probe ^{*3}	701933	30 Arms, DC to 50 MHz, supports probe power
Current Probe ^{*3}	701930	150 Arms, DC to 10 MHz, supports probe power
Current Probe ^{*3}	701931	500 Arms, DC to 2 MHz, supports probe power
Probe Power Supply ^{*4}	701934	Large current output, external probe power supply (4 outputs)
Shunt Resistor	438920	250 Ω±0.1%
Shunt Resistor	438921	100 Ω±0.1%
Shunt Resistor	438922	10 Ω±0.1%
Differential Probe	700924	1400 Vpk, 1000 Vrms-CAT II
Differential Probe	700925	500 Vpk, 350 Vrms (For 701255)
Differential Probe	701926	7000Vpk, 5000Vrms
Bridge Head (NDIS, 120 Ω/350 Ω)	701955/56	With 5 m cable
Bridge Head (DSUB, Shunt-CAL, 120 Ω/350 Ω)	701957/58	With 5 m cable
Safety BNC-banana Adapter	758924	500 Vrms-CAT II
Printer Roll Paper	B9988AE	For DL750, DL850, DL850V, 10 m x 10
Logic Probe ^{*5}	702911	8-Bit, 1 m, non-Isolated, TTL level/Contact Input
Logic Probe ^{*5}	702912	8-Bit, 3 m, non-Isolated, TTL level/Contact Input
High-speed Logic Probe ^{*5}	700986	8-Bit, non-Isolated, response speed: 1 μs
Isolated Logic Probe ^{*5}	700987	8-Bit, each channel isolated
Measurement Lead Set	758917	Measurement leads (2 per set) Alligator-Clip is required separately.
Safety BNC-BNC Cable (1 m)	701902	1000 Vrms-CAT II (BNC-BNC)
Safety BNC-BNC Cable (2 m)	701903	1000 Vrms-CAT II (BNC-BNC)
External I/O Cable	720911	For external I/O connection
Plug-On Clip	701948	For 700929 and 701947
Long Test Clip	701906	For 700924 and 701926
Terminal	A1800JD	For 720220 input terminal, one (1) piece
Soft Carrying Case	701963	For DL850/DL850V/DL750
Connecting cables	705926	Connecting cable for 701953 (1 m)
	705927	Connecting cable for 701953 (3 m)
DC Power Supply Cable (Alligator clip type)	701971	For DL850V DC12 V power
DC Power Supply Cable (Cigarette lighter plug type)	701970	For DL850V DC12 V power
DC Power Supply Connector	B8023WZ	It comes standard with the /DC option

*1 Actual allowable voltage is the lower of the voltages specified for the main unit and cable.

*2 42 V is safe when using the 701940 with an isolated type BNC input.

*3 The number of current probes that can be powered from the main unit's power supply is limited.

*4 Any number of externally powered probes can be used.

*5 Includes one each of the B9879PX and B9879KX connection leads.

*6 Additionally, 758917 and either the 758922 or 758929 are required for measurement.

<http://www.scopecorder.net/>

ScopeCorder Special Site

ScopeCorder Series
DL850

Product photos, videos and demonstrations are available at this dedicated web site. Download the latest DL850 brochure and specifications.

